



2022
BOLT EV

Everyday excitement.

The refreshed exterior and comfortable interior of the all-electric 2022 Bolt EV bring new energy every time you get behind the wheel.

But it's the near-instant torque as you accelerate through life that will really elevate your enthusiasm. And the unexpected way Bolt EV holds the open road will help make driving fun again.

Now consider Bolt EV fits seamlessly into your world in every way that matters – and does it all with an EPA-estimated 259 miles of range¹ on a full charge. That's something to really get excited about.



Bolt EV 2LT in Ice Blue Metallic.

¹EPA estimated. Actual range will vary based on several factors, including temperature, terrain, battery age, loading, use and maintenance.

ALL-ELECTRIC. ZERO TAILPIPE EMISSIONS.

Bolt EV at a glance.

- Redesigned exterior includes
 - Aerodynamic front and rear fascias
 - Sleek LED headlamps
 - Modern LED taillamps
 - Bold wheels
 - New color choices
- Updated interior, with comfortable seating for five
- Standard DC Fast Charging capable
- 57.0 cubic feet of maximum cargo space¹ with the rear seats folded flat
- 266 lb.-ft. of torque and 0 to 60 in 6.5 seconds²
- Chevy Safety Assist,³ standard on all models, includes
 - Automatic Emergency Braking
 - Front Pedestrian Braking
 - Lane Keep Assist with Lane Departure Warning
 - Forward Collision Alert
 - IntelliBeam[®] with automatic high beam on/off
 - Following Distance Indicator
- Infotainment technology includes
 - Wireless Apple CarPlay^{®4} compatibility
 - Wireless Android Auto^{™5} compatibility
 - Multiple energy efficiency screens
 - Available Alexa Built-In⁶
 - Available Chevrolet Maps+⁷



Bolt EV 1LT interior in Jet Black.



Bolt EV 2LT in Ice Blue Metallic.

¹ Cargo and load capacity limited by weight and distribution. ² Based on initial vehicle movement. ³ Safety or driver assistance features are no substitute for the driver's responsibility to operate the vehicle in a safe manner. Read the vehicle Owner's Manual for important feature limitations and information. ⁴ Vehicle user interface is a product of Apple and its terms and privacy statements apply. Requires compatible iPhone and data plan rates apply. ⁵ Vehicle user interface is a product of Google and its terms and privacy statements apply. Requires the Android Auto app on Google Play and a compatible Android smartphone. Data plan rates apply. You can check which smartphones are compatible at g.co/androidauto/requirements. ⁶ Functionality is subject to limitations and varies by vehicle, infotainment system and location. Select service plan required. Certain Alexa Skills require account linking to use. Visit onstar.com for additional details. ⁷ U.S. only. Requires select service plan. Functionality is subject to user terms and limitations and varies by vehicle model. Visit onstar.com for details and limitations.

Apple CarPlay, iPhone, Siri and Apple Music are trademarks of Apple Inc., registered in the U.S. and other countries. Android, Google Play and Android Auto are trademarks of Google LLC.

RANGE/CHARGING

Range.

- An EPA-estimated 259 miles of pure electric range¹ on a full charge
- Efficiency technologies like Regen on Demand² and One Pedal Driving³ also make Bolt EV a joy to drive
- Michelin[®] Energy[™] Saver All-Season tires with Selfseal[®] technology
- myChevrolet Mobile App⁴ with Energy Assist uses real-time information to calculate the most efficient route
- Range Impacts Screen shows how select factors can affect range
- Efficiency History Screen displays energy efficiency for the previous 50 miles



Standard Regen on Demand² technology.

PLUG-IN PROMISE

Your electric one-stop shop to charge ahead with confidence. Plug-In Promise includes

- A hassle-free 240-volt outlet installation provided exclusively by Qmerit
- Help locating more than 40,000 compatible charging stations through the Energy Assist feature on the myChevrolet Mobile App⁴
- Access to an EV Concierge
- Chevy MyWay⁵ live experience with a product specialist who is ready to answer all of your questions
- Exclusive 8-year/100,000-mile⁶ Electric and Hybrid Vehicle Limited Warranty Coverage and Courtesy Transportation

Many easy ways to charge.

Basic	Fast	Faster	Fastest
<p>LEVEL 1 120-volt Standard Charge Cord</p> <p>Charge with a 3-prong outlet</p> <p>About 4 miles of range per hour of charge⁸</p>	<p>LEVEL 2 240-volt Available Dual Level Charge Cord⁷</p> <p>Hassle-free 240-volt outlet installation provided by Qmerit</p> <p>About 26 miles of range per hour of charge⁸</p>	<p>LEVEL 2 240-volt 48-amp Charging Unit</p> <p>Fastest way to charge at home</p> <p>About 39 miles of range per hour of charge^{8,9}</p>	<p>DC FAST CHARGING</p> <p>Offers accelerated charging while you're away from home</p> <p>Available at public stations only</p> <p>Up to 100 miles of range in about 30 minutes¹⁰</p>

¹ EPA estimated. Actual range will vary based on several factors, including temperature, terrain, battery age, loading, use and maintenance. ² Feature may be limited when the battery temperatures are extremely cold or hot or when battery is near full charge. See Owner's Manual for details. ³ Feature may be limited when the battery temperatures are extremely cold or hot or when battery is near full charge. Always use the brake pedal when you need to stop immediately. See Owner's Manual for details. ⁴ Available on select Apple and Android devices. Service availability, features and functionality vary by vehicle, device and the plan you are enrolled in. Terms apply. Device data connection required. Visit onstar.com and chevrolet.com for details and limitations. Energy Assist does not provide turn-by-turn navigation. ⁵ Chevy MyWay is available to anyone over 18 in the United States to access and experience via chevrolet.com/myway. ⁶ Whichever comes first. See dealer for details. ⁷ Late availability. ⁸ Actual charge times will vary based on battery condition, output of charger, vehicle settings and outside temperature. See Owner's Manual for additional limitations. ⁹ Requires 11.5-kW (48-amp) charging unit. Charging unit not currently available through Chevrolet. See Owner's Manual for additional limitations. ¹⁰ Actual charge times will vary based on battery starting state of charge, battery condition, output of charger, vehicle settings and outside temperature. See Owner's Manual for additional limitations.

MODELS

Two models to choose from.

You can't go wrong when you're choosing an all-electric future in Bolt EV.



1LT

Bolt EV 1LT has the features, style and value that prove there is an electric vehicle for everybody.

- 17-inch Silver-painted aluminum wheels
- DC Fast Charging capable
- 11.5-kW charging module
- HD Rear Vision Camera¹
- Chevy Safety Assist²
- Cloth front bucket seats
- Flat-bottom steering wheel with Black bowtie emblem
- 10.2-inch diagonal color touch-screen
- Wireless Apple CarPlay^{®3} and wireless Android Auto^{®4} compatibility
- Keyless Open and Start
- Remote vehicle starter system

2LT

When you want an electric vehicle that never compromises on comfort and delivers a number of additional driver assistance features, look no further than Bolt EV 2LT.

- 17-inch machined-face aluminum wheels with Carbon Flash-painted pockets
- Rear Cross Traffic Alert¹
- Rear Park Assist¹
- HD Surround Vision¹
- Lane Change Alert with Side Blind Zone Alert¹
- Leather-appointed seating surfaces
- Heated front seats
- 8-way power driver seat
- Heated leather-wrapped steering wheel
- Available Adaptive Cruise Control¹

¹ Safety or driver assistance features are no substitute for the driver's responsibility to operate the vehicle in a safe manner. Read the vehicle Owner's Manual for important feature limitations and information. ² Chevy Safety Assist includes Automatic Emergency Braking, Front Pedestrian Braking, Lane Keep Assist with Lane Departure Warning, Forward Collision Alert, IntelliBeam and Following Distance Indicator. Safety or driver assistance features are no substitute for the driver's responsibility to operate the vehicle in a safe manner. Read the vehicle Owner's Manual for important feature limitations and information. ³ Vehicle user interface is a product of Apple and its terms and privacy statements apply. Requires compatible iPhone and data plan rates apply. ⁴ Vehicle user interface is a product of Google and its terms and privacy statements apply. Requires the Android Auto app on Google Play and a compatible Android smartphone. Data plan rates apply. You can check which smartphones are compatible at g.co/androidauto/requirements.

1LT EXTERIOR COLORS



Summit White



Silver Flare Metallic



Gray Ghost Metallic



Cherry Red Tintcoat¹



Ice Blue Metallic



Bright Blue Metallic¹



Mosaic Black Metallic

¹Extra-cost color.

1LT FEATURES



Select standard features:

MECHANICAL

Battery – propulsion, 65 kWh lithium-ion Rechargeable Energy Storage System

Charge Cord – 120-volt, portable

Charging – DC Fast Charging capability

Charging module – 11.5 kW high-voltage

Electric drive unit – 200 hp (150 kW) of motoring power, 266 lb.-ft. (360 Nm) of motoring torque

Electronic Precision Shift – electronic transmission range selector button and trigger-based drive unit interface; includes One Pedal Driving button¹

Regen on Demand² – driver-initiated regenerative braking, steering wheel-mounted paddle

EXTERIOR

Headlamps – LED with automatic on/off

Mirrors – heated, power-adjustable, manual-folding

INTERIOR

Air conditioning – automatic, single-zone with cabin air filter and humidity sensor

Chevy Safety Assist³ – Automatic Emergency Braking, Front Pedestrian Braking, Lane Keep Assist with Lane Departure Warning, Forward Collision Alert, IntelliBeam with automatic high beam on/off and Following Distance Indicator

Entertainment – Chevrolet Infotainment 3 Plus system⁴ with 10.2-inch diagonal HD color touch-screen

Keyless Open and Start

Remote vehicle starter system – includes Remote Keyless Entry

Steering wheel – deluxe, flat-bottom with Black bowtie emblem and steering wheel-mounted controls including Regen on Demand regenerative braking paddle and audio, cruise and phone controls

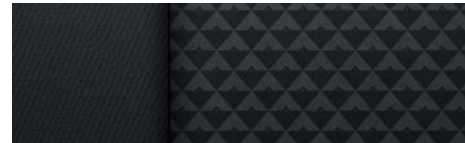

Jet Black Cloth



17" Silver-Painted Aluminum Wheels
Standard on 1LT



17" Machined-Face Aluminum Wheels
with Carbon Flash-Painted Pockets
Available on 1LT

¹ Feature may be limited when the battery temperatures are extremely cold or hot or when battery is near full charge. Always use the brake pedal when you need to stop immediately. See Owner's Manual for details. ² Feature may be limited when the battery temperatures are extremely cold or hot or when battery is near full charge. See Owner's Manual for details. ³ Safety or driver assistance features are no substitute for the driver's responsibility to operate the vehicle in a safe manner. Read the vehicle Owner's Manual for important feature limitations and information. ⁴ Chevrolet Infotainment System functionality varies by model. Full functionality requires compatible Bluetooth and smartphone, and USB connectivity for some devices.

2LT EXTERIOR COLORS



Summit White



Silver Flare Metallic



Gray Ghost Metallic



Cherry Red Tintcoat¹



Ice Blue Metallic



Bright Blue Metallic¹



Mosaic Black Metallic

¹Extra-cost color.

2LT FEATURES



Select standard features:

MECHANICAL

Battery – propulsion, 65 kWh lithium-ion Rechargeable Energy Storage System

Charge Cord – 120-volt, portable

Charging – DC Fast Charging capability

Charging module – 11.5 kW high-voltage

Electric drive unit – 200 hp (150 kW) of motoring power, 266 lb.-ft. (360 Nm) of motoring torque

Electronic Precision Shift – electronic transmission range selector button and trigger-based drive unit interface; includes One Pedal Driving button¹

Regen on Demand² – driver-initiated regenerative braking, steering wheel-mounted paddle

INTERIOR

Armrest – rear-seat center with cup holders

Chevy Safety Assist³ – Automatic Emergency Braking, Front Pedestrian Braking, Lane Keep Assist with Lane Departure Warning, Forward Collision Alert, IntelliBeam with automatic high beam on/off and Following Distance Indicator

Entertainment – Chevrolet Infotainment 3 Plus system⁴ with 10.2-inch diagonal HD color touch-screen

HD Surround Vision³ – includes HD Rear Vision Camera³

Lane Change Alert with Side Blind Zone Alert³

Lighting – ambient LED-based door lighting

Mirror – rearview, auto-dimming

Rear Cross Traffic Alert³

Rear Park Assist³

Seat – driver 8-way power adjuster with 2-way power lumbar control

Seats – heated front seats

Steering wheel – leather-wrapped, heated with selectable automatic activation



Jet Black Perforated Leather-Appointed Seating Surfaces



17" Machined-Face Aluminum Wheels
with Carbon Flash-Painted Pockets
Standard on 2LT

¹ Feature may be limited when the battery temperatures are extremely cold or hot or when battery is near full charge. Always use the brake pedal when you need to stop immediately. See Owner's Manual for details. ² Feature may be limited when the battery temperatures are extremely cold or hot or when battery is near full charge. See Owner's Manual for details. ³ Safety or driver assistance features are no substitute for the driver's responsibility to operate the vehicle in a safe manner. Read the vehicle Owner's Manual for important feature limitations and information. ⁴ Chevrolet Infotainment System functionality varies by model. Full functionality requires compatible Bluetooth and smartphone, and USB connectivity for some devices.

SPECIFICATIONS

● STANDARD ○ AVAILABLE – NOT AVAILABLE

	1LT	2LT
SAFETY AND DRIVER ASSISTANCE		
Chevy Safety Assist ¹	●	●
Automatic Emergency Braking		
Front Pedestrian Braking		
Lane Keep Assist with Lane Departure Warning		
Forward Collision Alert		
IntelliBeam, auto high beams		
Following Distance Indicator		
Airbags ² – frontal and knee airbags for driver and front passenger; seat-mounted side-impact airbags and head-curtain airbags for all outboard seating positions; includes Passenger Sensing System for passenger-side frontal and knee airbags	●	●
HD Rear Vision Camera ¹	●	–
HD Surround Vision ¹ – includes HD Rear Vision Camera ¹	–	●
Lane Change Alert with Side Blind Zone Alert ¹ (requires available Driver Confidence Package on 1LT)	○	●
LATCH system (Lower Anchors and Tethers for CHildren) – for child restraint systems	●	●
Pedestrian Safety Signal – automatic passive audible tone during low-speed operation	●	●
Rear Cross Traffic Alert ¹ (requires available Driver Confidence Package on 1LT)	○	●
Rear Park Assist ¹ (requires available Driver Confidence Package on 1LT)	○	●
Teen Driver technology	●	●
Theft-deterrent system – content-theft alarm	●	●
– propulsion immobilizer	●	●
– unauthorized entry	●	●
Tire Pressure Monitoring System – with Tire Fill Alert	●	●
Up to 3 months of OnStar [®] Safety & Security coverage ³	●	●

	1LT	2LT
MECHANICAL		
Battery – 12-volt with rundown protection	●	●
– propulsion, 65 kWh lithium-ion Rechargeable Energy Storage System	●	●
Brakes – 4-wheel antilock, 4-wheel disc; electronic parking brake	●	●
Charge control – location-based, selectable GPS-enabled with programmable home charging setting and programmable time of day with charging status indicator light on instrument panel	●	●
Charge cord – 120-volt, portable	●	●
– Dual Level Charge Cord, 120-volt and 240-volt capability, portable (late availability)	○	○
Charging – DC Fast Charging capability	●	●
Charging module – 11.5 kW high-voltage	●	●
Driver Selected Operating Modes – Normal and Sport	●	●
Electric drive unit – 200 hp (150 kW) of motoring power, 266 lb.-ft. (360 Nm) of motoring torque	●	●
Electronic Precision Shift – electronic transmission range selector button and trigger-based drive unit interface; includes One Pedal Driving ⁴ button	●	●
Regen on Demand ⁵ – driver-initiated regenerative braking, steering wheel-mounted paddle	●	●
StabiliTrak [®] – Electronic Stability Control System with Traction Control	●	●
Steering – power, electric	●	●
Suspension – Performance Ride and Handling, front independent MacPherson strut; rear semi-independent with compound crank	●	●

¹ Safety or driver assistance features are no substitute for the driver's responsibility to operate the vehicle in a safe manner. Read the vehicle Owner's Manual for important feature limitations and information. ² A NOTE ON CHILD SAFETY: Always use seat belts and the correct child restraint for your child's age and size, even with airbags. Even in vehicles equipped with the Passenger Sensing System, children are safer when properly secured in a rear seat in the appropriate infant, child or booster seat. Never place a rear-facing infant restraint in the front seat of any vehicle equipped with an active frontal airbag. See your vehicle Owner's Manual and the child safety seat instructions for more safety information. ³ When you select a monthly plan within 30 days of activating your 1-month trial, you'll receive the next 2 months of the plan you select at no additional charge when you associate an approved payment method on file to your account and authorize recurring payments for your service plan. The amount and frequency of each recurring payment is based upon the service(s) and payment interval(s) you select from the options provided. After the trial expires, OnStar will automatically bill your payment method monthly at then-current standard monthly rates. Plans containing 4G LTE data will be billed every 30 days by AT&T. You may cancel at any time by pushing your blue OnStar button or calling 1-888-466-7827. May not be combined with other offers or retroactively applied. Offer subject to change. ⁴ Feature may be limited when the battery temperatures are extremely cold or hot or when battery is near full charge. Always use the brake pedal when you need to stop immediately. See Owner's Manual for details. ⁵ Feature may be limited when the battery temperatures are extremely cold or hot or when battery is near full charge. See Owner's Manual for details.

SPECIFICATIONS (CONTINUED)

● STANDARD ○ AVAILABLE – NOT AVAILABLE

	1LT	2LT
EXTERIOR		
Chevrolet bowtie emblems – Black	●	●
Daytime running lamps – LED with signature lighting	●	●
Door handles – body-color	●	●
Glass – solar-absorbing	●	●
Headlamps – LED with automatic on/off – IntelliBeam with automatic high beam on/off	●	●
Mirrors – heated, power-adjustable, manual-folding	●	●
Taillamps – LED	●	●
Tires – P215/50R17 Michelin® Energy™ Saver All-Season with Selfseal® technology	●	●
Wheels – 17" Silver-painted aluminum – 17" machined-face aluminum with Carbon Flash-painted pockets	●	–
Wipers – front variable-speed, intermittent with washers – rear intermittent with washer	●	●
INTERIOR		
Air conditioning – automatic, single-zone with cabin air filter and humidity sensor	●	●
Armrest – rear-seat center with cup holders	–	●
Cargo area – cargo cover – false cargo floor storage area	●	●
Console – front with covered storage	●	●
Cruise control – electronic with Set and Resume Speed – Adaptive Cruise Control ¹ (requires available Infotainment Package)	●	●
Door locks – power programmable with lockout protection and manual rear door child security	●	●
Driver Information Center – 8-inch diagonal enhanced multi-color configurable graphic display with two themes and energy-use monitors	●	●

	1LT	2LT
INTERIOR (CONTINUED)		
Floor mats – front and rear carpeted	●	●
Lighting – ambient LED-based lighting, front reading lamps, dome lamp and incandescent cargo area lamp – ambient LED-based instrument panel lighting	●	●
Mirror – rearview, manual day/night – rearview, auto-dimming (requires available Comfort and Convenience Package on 1LT)	●	–
Rear-seat heat ducts	○	●
Remote Keyless Entry – extended-range with panic alarm – Keyless Open and Start	●	●
Remote vehicle starter system	●	●
Steering column – manual tilt and telescopic	●	●
Steering wheel – deluxe, flat-bottom with Black bowtie emblem and steering wheel-mounted controls including Regen on Demand ² regenerative braking paddle and audio, cruise and phone controls – leather-wrapped (requires available Comfort and Convenience Package on 1LT) – heated with selectable automatic activation (requires available Comfort and Convenience Package on 1LT)	●	●
Visors – driver and front passenger, covered vanity mirrors, sliding	○	●
Windows – power with driver express-up/-down, all others express-down	○	●
SEATING		
Seats – front bucket – rear manual-folding 60/40 split-bench	●	●
Seat – driver 6-way manual adjuster – driver 8-way power adjuster with 2-way power lumbar control (requires available Comfort and Convenience Package on 1LT) – front passenger 6-way manual adjuster – front passenger seatback map pocket	●	–
Heated front seats (requires available Comfort and Convenience Package on 1LT)	○	●

¹ Safety or driver assistance features are no substitute for the driver's responsibility to operate the vehicle in a safe manner. Read the vehicle Owner's Manual for important feature limitations and information. ² Feature may be limited when the battery temperatures are extremely cold or hot or when battery is near full charge. See Owner's Manual for details.

SPECIFICATIONS (CONTINUED)

● STANDARD ○ AVAILABLE – NOT AVAILABLE

	1LT	2LT
ENTERTAINMENT		
Chevrolet Infotainment 3 Plus system ¹ with 10.2-inch diagonal HD color touch-screen, AM/FM stereo, Bluetooth [®] audio streaming ² for two active devices, wireless Apple CarPlay ^{®3} and wireless Android Auto ^{™4} compatibility, available Alexa Built-In ⁵ ; voice recognition, available In-Vehicle Apps ⁶ ; Chevrolet Maps+ ⁷ and vehicle efficiency display with programmable charge times	●	●
Audio – 6-speaker system – Bose premium 7-speaker audio system including subwoofer (requires available Infotainment Package)	●	●
Media – two USB ports ⁸ ; one Type-A and one Type-C, SD card reader and auxiliary input jack in front center console – two USB ports ⁸ ; one Type-A and one Type-C, charge-only, on rear of center console (requires available Infotainment Package)	●	●
SiriusXM [®] with 360L ⁹ – 3-month trial subscription	●	●
Available Wi-Fi [®] Hotspot ¹⁰ for up to seven devices, includes 1 month of unlimited data	○	○
Chevrolet Connected Access ¹¹ with up to 10 years of standard connectivity, which currently enables features such as Vehicle Diagnostics and Dealer Maintenance Notification	●	●
Chevrolet EV Access ¹² with up to 10 years of standard connectivity, which currently enables features such as Charge Status, Route Planning, Energy Notifications and more	●	●
Wireless device charging ¹³ (requires available Infotainment Package)	–	○

	1LT	2LT
PACKAGES		
Driver Confidence Package ¹⁴	○	●
Lane Change Alert with Side Blind Zone Alert, Rear Cross Traffic Alert and Rear Park Assist	○	●
Comfort and Convenience Package	○	●
Driver 8-way power seat adjuster with 2-way power lumbar control, heated front seats, heated leather-wrapped steering wheel, and inside auto-dimming rearview mirror (requires available Driver Confidence Package on 1LT)	○	●
Infotainment Package	–	○
Bose premium 7-speaker audio system and two USB ports ⁸ ; one Type-A and one Type-C, charge-only, on rear of center console	–	○

¹ Chevrolet Infotainment System functionality varies by model. Full functionality requires compatible Bluetooth and smartphone, and USB connectivity for some devices. ² Go to my.chevrolet.com/learnAbout/bluetooth to find out which phones are compatible with the vehicle. Full Bluetooth feature functionality varies by device, model and software version. ³ Vehicle user interface is a product of Apple and its terms and privacy statements apply. Requires compatible iPhone and data plan rates apply. ⁴ Vehicle user interface is a product of Google and its terms and privacy statements apply. Requires the Android Auto app on Google Play and a compatible Android smartphone. Data plan rates apply. You can check which smartphones are compatible at g.co/androidauto/requirements. ⁵ Functionality is subject to limitations and varies by vehicle, infotainment system and location. Select service plan required. Certain Alexa Skills require account linking to use. Visit onstar.com for additional details. ⁶ Third-party trademarks are the property of their respective third-party owners and used under agreement. Requires active service plan and paid AT&T vehicle data plan. Visit onstar.com for details and limitations. ⁷ U.S. only. Requires select service plan. Functionality is subject to user terms and limitations and varies by vehicle model. Visit onstar.com for details and limitations. ⁸ Not compatible with all devices. ⁹ If you decide to continue service after your trial, your selected subscription plan will automatically renew thereafter. You will be charged at then-current rates. Fees and taxes apply. To cancel you must call SiriusXM at 1-866-635-2349. See SiriusXM Customer Agreement for complete terms at siriusxm.com. All fees and programming subject to change. ¹⁰ Service varies with conditions and location. Requires active service and paid AT&T data plan. Visit onstar.com for details and limitations. Availability subject to change. ¹¹ Standard connectivity available only to original purchaser for up to 10 years. Connected Access services are subject to change. Does not include emergency or security services. Diagnostic capabilities vary by model and service plan. Message and data rates may apply. Requires contact method on file and enrollment to receive alerts. Not all issues will deliver alerts. Visit onstar.com for details and limitations. ¹² Included for up to the first 10 years of ownership, then requires select plan subscription. Services enabled by EV Access package are subject to change. Energy Assist feature does not provide turn-by-turn navigation. Does not include emergency or security services. Visit onstar.com for details and limitations. ¹³ The system wirelessly charges one compatible mobile device. Some phones have built-in wireless charging technology and others require a special adaptor/back cover. To check for phone or other device compatibility, see my.chevrolet.com/learn or consult your carrier. ¹⁴ Safety or driver assistance features are no substitute for the driver's responsibility to operate the vehicle in a safe manner. Read the vehicle Owner's Manual for important feature limitations and information.

SPECIFICATIONS (CONTINUED)

MAXIMUM CAPACITIES

Battery	65 kWh
Passenger volume	93.9 cubic feet
Seating (front/rear)	Seats 2/3
Cargo volume ¹	Behind second-row seat: 16.6 cubic feet Behind front seats (with rear seat folded): 57.0 cubic feet

DIMENSIONS

A - Wheelbase	102.4"
B - Length	163.2"
C - Height	63.4"

EPA-ESTIMATED FUEL ECONOMY

EV range	259 miles ² with a full charge
Combined	120 MPGe

BOLT EV CHARGING SPECS

Charger type	Miles of range per hour of charge ³	Approximate time needed for a 0%-100% full charge ³
120-volt portable cord	About 4 miles	55 hours
240-volt charging unit	About 39 miles ⁴	7 hours
DC Fast Charging	Up to 100 miles in 30 minutes ⁵	N/A

D - Front track	59.1"
Rear track	59.1"
E - Width	69.5"

Head room (front/rear)	40.1"/37.9"
Leg room (front/rear)	44.3"/36.0"
Shoulder room (front/rear)	54.6"/52.8"
Hip room (front/rear)	51.3"/50.6"

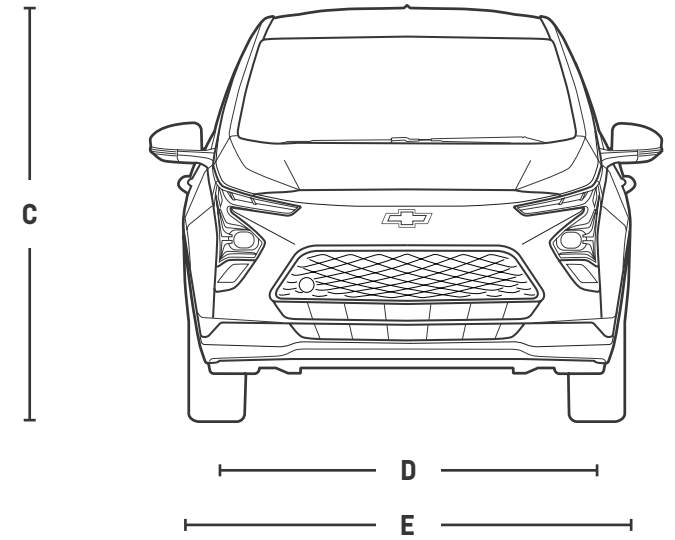
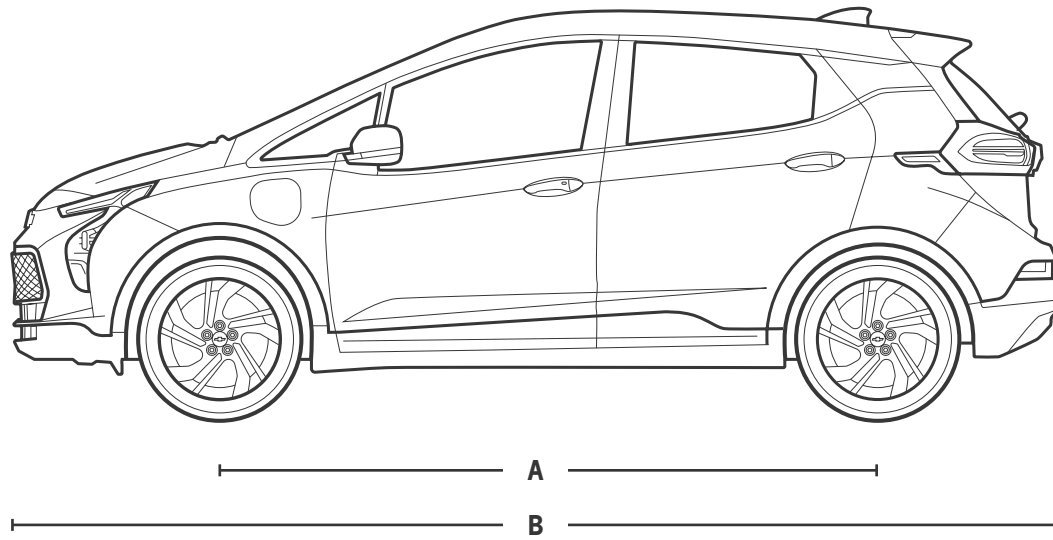

¹ Cargo and load capacity limited by weight and distribution. ² EPA estimated. Actual range will vary based on several factors, including temperature, terrain, battery age, loading, use and maintenance. ³ Actual charge times will vary based on battery condition, output of charger, vehicle settings and outside temperature. ⁴ Requires 11.5-kW (48-amp) charging unit. Charging unit not currently available through Chevrolet. ⁵ Actual charge times will vary based on battery starting state of charge, battery condition, output of charger, vehicle settings and outside temperature.

ACCESSORIES



All-Weather Floor Mats available from Chevrolet Accessories.



Illuminated Charge Port available from Chevrolet Accessories!



Cargo Net available from Chevrolet Accessories.



All-Weather Cargo Mat available from Chevrolet Accessories.

IMPORTANT INFORMATION



Every step of the way.

You may be discovering Chevrolet through a personalized online shopping experience or enjoying every year of vehicle ownership. Either way, we're committed to providing the tools and programs you need to help you get the most out of your journey.

Build & Price >

Create your perfect Chevrolet from start to finish.

Chevy MyWay¹ >

Engage in a real-time virtual video experience with a Chevy product specialist.

Chevrolet Complete Care >

Enjoy an owner benefit program that provides excellent service and support from day one.

Discover My Chevrolet Rewards² >

Unlock a world of appreciation that's all about you and your Chevrolet. Start earning and redeeming today.

Limited Warranty Coverage >

Discover all the ways Chevrolet is committed to providing an excellent ownership experience.



GM, the GM logo, Chevrolet, the Chevrolet logo, and the slogans, emblems, vehicle model names, vehicle body designs and other marks appearing in this brochure are the trademarks and/or service marks of General Motors, its subsidiaries, affiliates or licensors. ©2022 OnStar LLC. All rights reserved. Sirius, XM, SiriusXM and all related marks and logos are trademarks of Sirius XM Radio Inc. Amazon, Alexa and all related marks are trademarks of Amazon.com, Inc. or its affiliates. The Bluetooth word mark is a registered trademark owned by Bluetooth SIG, Inc., and any use of such mark by Chevrolet is under license. Bose is a registered trademark of the Bose Corp. Michelin and Selfseal are registered trademarks and Energy is a trademark of Michelin North America, Inc.

©2022 General Motors. All rights reserved. April 2022

FIND NEW ROADS[™]

CHEVROLET.COM

¹ Chevy MyWay is available to anyone over 18 in the United States to access and experience via chevrolet.com/myway. ² Must be 18 years or older. Points may be earned and redeemed only at GM entities, My Chevrolet Rewards participating dealers or third party retailers in the United States (excluding Puerto Rico, the U.S. Virgin Islands or Guam). Points are not earned on taxes, fees or body shop repair orders and expire without further notice upon Member Account deactivation. Visit myChevroletrewards.com to view My GM Rewards Terms & Conditions.